

DRIVE RING

COMPLETE ASSEMBLY  
EST WT = 469 lb [213 kg]

DRIVE RING & FRICTION DISCS  
EST WT = 55.1 lb [25 kg]  
EST WR<sup>2</sup> = 19.8 lb-ft<sup>2</sup> [0.832 kg-m<sup>2</sup>]

ALL ROTATING MEMBERS (PTO ENGAGED)  
EST WR<sup>2</sup> = 23.3 lb-ft<sup>2</sup> [0.981 kg-m<sup>2</sup>]

1 CUSTOMER SUPPLIED OUTBOARD SUPPORT  
PLATE IS REQUIRED FOR SIDELOAD APPLICATIONS  
AND RECOMMENDED FOR IN-LINE APPLICATIONS.

16 x Ø 0.531 [13.49] THRU ALL  
Ø 26.750 [679.45] H.C.

1-8 UNC  
BOTH SIDES

2 x 7/16-14 UNC  
180° APART

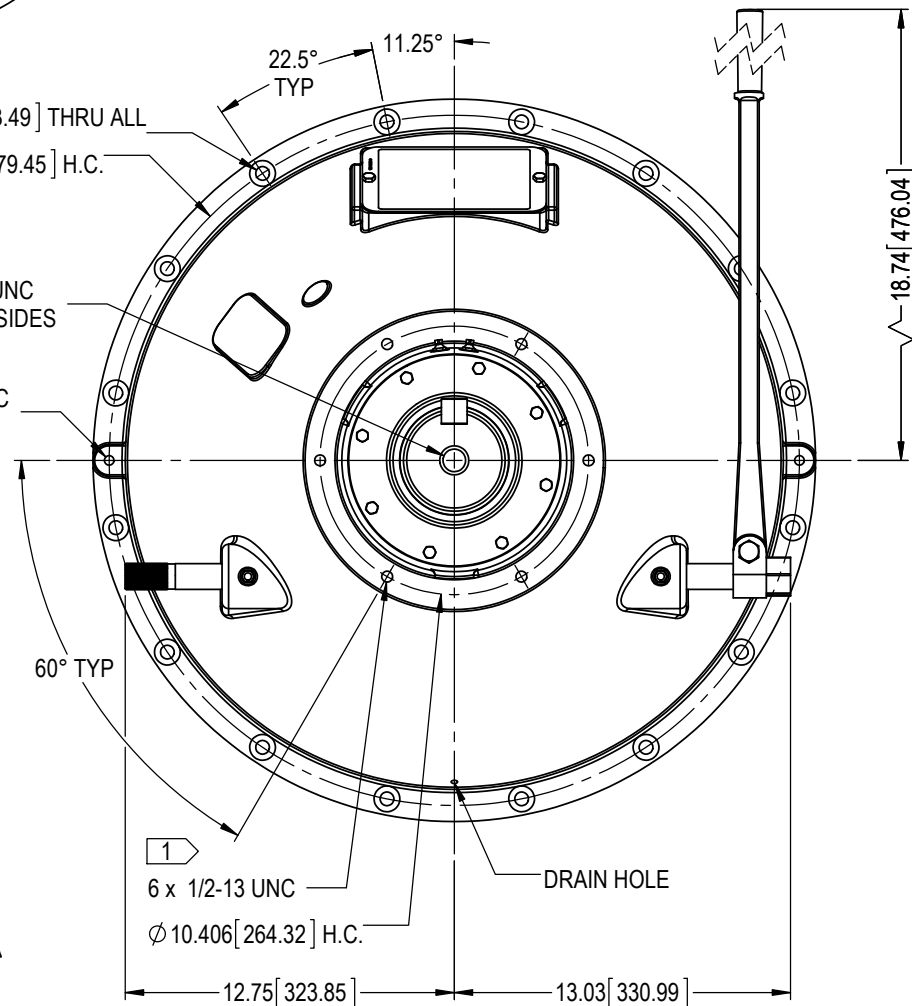

SECTION A-A

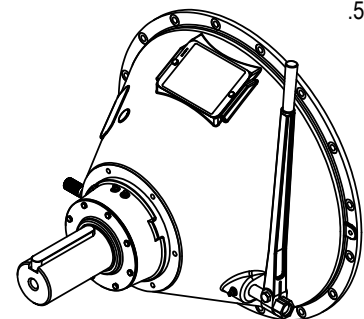
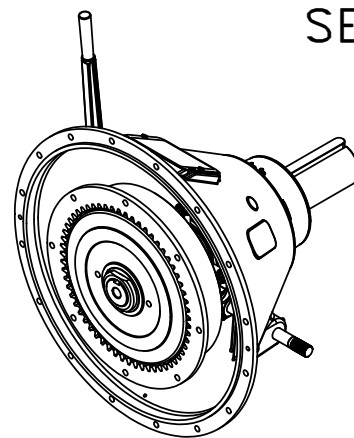

E	EC013410	29 Sep 17	RC
D	EC012197	14 Jan 16	RC
C	EC012142	31 Dec 15	RC
REV	REVISIONS	DATE	BY

WPT POWER CORPORATION ENGINEERING DRAWINGS ARE NOT TO BE REPRODUCED IN ANY FORM WHATSOEVER WITHOUT AUTHORIZATION	
DRAWN RC	DATE 22 Sep 15
CHECKED RDH	DATE 09 Oct 15
APPROVED BDS	DATE 10/9/2015
ISSUED RC	DATE 09 Oct 15

**WPT POWER CORPORATION**  
WPL314 MECH PTO, SAE #0  
BELLHOUSING, SEALED BALL BEARING  
COLLAR, PILOTLESS

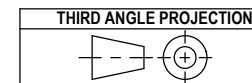

PART NUMBER WTD-14-306	REVISION E	SHEET 1	OF 1
---------------------------	---------------	------------	---------